



Powered by  
**BINGSHAN**  
PROFESSIONAL REFRIGERATION

☎ (+52) 55 7901 5824

✉ [Iceballos@frigoespacios.com](mailto:Iceballos@frigoespacios.com)

---

FRIGOESPACIOS.COM



Powered by  
**BINGSHAN**  
PROFESSIONAL REFRIGERATION



Falling Film Semi-hermetic Screw >>  
Water Chiller/Heat pump/Glycol/Brine unit

Dalian Bingshan Engineering & Trading Co.,Ltd.

## Features

- ▶ Adopt high-efficiency reliable semi-hermetic screw compressor unit
- ▶ High-efficiency falling film evaporator
- ▶ Adopt opening control algorithm of electronic expansion valve
- ▶ Suit for the regular chilled water, -20°C brine water and 80°C hot water as well.
- ▶ High-efficiency & low-resistance horizontal external oil separator
- ▶ Reliable self-protection
- ▶ 8" touch screen and easy to operate
- ▶ Real time monitoring and flexible extend

## Falling Film Semi-hermetic Screw Water Chiller/Heat pump/Glycol/Brine unit



### LS series falling film semi-hermetic screw water chiller

Single-compressor Ref. Cap. (55RT-420RT) 193kW--1475kW  
 Dual-compressor Ref. Cap. (330RT-835RT) 1161kW--2937kW

### RB series falling film semi-hermetic screw water/ground source heat pump unit

Single-compressor Ref. Cap. (80RT-578RT) 278kW--2021kW  
 Dual-compressor Ref. Cap. (465RT-1179RT) 1626kW--4127kW

### YC series falling film semi-hermetic glycol screw chiller

Single-compressor Ref. Cap. (28RT-202RT) 98kW--709kW  
 Dual-compressor Ref. Cap. (160RT-403RT) 564kW--1418kW

### YS series falling film semi-hermetic brine screw chiller

Single-compressor Ref. Cap. (28RT-202RT) 98kW--709kW  
 Dual-compressor Ref. Cap. (160RT-403RT) 564kW--1418kW

## Application

- ▶ Providing low-temperature chilled water and high-temperature hot water for air conditioning, and providing various temperature glycol and brine for processing.
- ▶ Widely used in theater, hotels, shopping malls, hospitals, restaurants, office buildings and other comfort air-conditioning systems; and the cooling of electromechanical equipment, the production of instrumentation, textile, printing and other industrial air-conditioning system; and also widely used in various industrial production fields which need low-temperature brine.

## Product Model Instruction

- Model instructions of BingShan Falling Film Semi-hermetic Screw Water Chiller are as follows:

LS            185            A 1 A  
①            ②            ③ ④ ⑤

Nº	Code	Meaning
①	LS	Falling Film Semi-hermetic Screw Water Chiller
	RB	Falling Film Semi-hermetic Screw Water/Ground Source Heat Pump Unit
	YC	Falling Film Semi-hermetic Glycol Screw Chiller
	YS	Falling Film Semi-hermetic Brine Screw Chiller
②	185	Nominal Cooling Capacity: RT(USRT), 10-1 times of nominal heating capacity for RB series
③	A	Refrigerant code: A for R134a, B for R22
④	1	"1" for single-compressor, "2" for dual-compressor
⑤	A	"A" for Standard High-Efficiency product, "B, C, D,.....O" for High-Efficiency products which functions and performance have changed correspondingly
	P	"P" for Standard Super-Efficiency product, "Q, R, S,.....Z" for Super-Efficiency products which functions and performance have changed correspondingly.

Note :

- LS series provide following optional functions:
  - Heat recovery;
  - Ice thermo storage;
  - Pressure of heat exchanger side: 1.6MPa and 2.0MPa;
- There are many optional application conditions for both using side and heat source side of RB series water(ground) source heat pump unit, this catalogue only lists technical parameters of water circulation condition for model selection, and for detailed data of other conditions, including the working condition of groundwater and ultra-high temperature hot water(water outlet temperature higher than 80°C), please contact with us.
- If YC/YS series glycol/brine chiller are used under the circumstances of glycol/brine water outlet temperature below -10°C, economizer and oil cooler are provided, please connect us if necessary.
- YC series units are only suitable for glycol as secondary refrigerant. The YS series units can be used for secondary refrigerants such as calcium chloride and sodium chloride.

## Working Conditions

- The working conditions of LS series water chiller should meet GB/T 18430.1 requirements as below

		Max.Max.(°C)	Min.Min.(°C)
Cooling Water	Water inlet temp.	40	19
	Temp.diff.	10	3
Chilled Water	Water outlet temp.	15	2
	Temp.diff.	10	3
Voltage Deviation		- 5 ~ + 5%	

The chilled water and cooling water quality should meet GB50050-95 requirements in <Industrial circulating cooling water treatment> and GB/T18430.1-2007 requirements in Appendix D.

- The refrigerating conditions of RB series water (ground) source heat pump unit has the same working conditions as LS series water chiller, and the heating conditions meets GB/T19409 requirements below

		Max.(°C)	Min.(°C)
Cooling Water	Water inlet temp.	40	19
	Temp.diff.	10	3
Chilled Water	Water outlet temp.	15	2
	Temp.diff.	10	3
Voltage Deviation		- 5 ~ + 5%	

Using side and heat source side water quality should meet GB50050-95 requirements in <Industrial circulating cooling water treatment> and GB/T18430.1-2007 requirements in Appendix D.

- The working conditions of YC/YS series glycol/brine chiller are listed in the table below

		Max.(°C)	Min.(°C)
Cooling Water	Water inlet temp.	33	5
	Temp.diff.	10	3
Glycol/Brine	Water outlet temp.	2	-23
	Temp.diff.	5	1.5

If the glycol / brine outlet temperature is relatively high, and the cooling water inlet temperature is relatively low, it is necessary to adjust the cooling water flow properly to ensure the normal operation of the unit

- Advice for the preparation of glycol/brine solution
 

To prepare glycol solution, optimal grade glycol stipulated in GB4649 in <Industrial Glycol> and water which quality meets GB50050 requirements in <Industrial circulating cooling water treatment> are mixed into appropriate concentration solution, and add an appropriate amount of corrosion inhibitor to adjust the pH of the solution above 7, or use the refrigerating air-conditioner special glycol to prepare.

To prepare calcium chloride solution, first grade calcium chloride dehydrate stipulated in HG/T2327 in <Industrial calcium chloride> and water which quality meets GB50050 requirements in <Industrial circulating cooling water treatment> are mixed into appropriate concentration solution.

To prepare sodium chloride solution, first grade industrial salt stipulated in GB5462 in <Industrial salt> and water which quality meets GB50050 requirements in <Industrial circulating cooling water treatment> are mixed into appropriate concentration solution.

## Technical Advantage

The advantages of BingShan Falling Film Semi-hermetic Screw Water chiller are mainly reflected in the following six aspects:

### 1. High performance semi-hermetic dual-compressor screw unit

Introducing the modern fourth generation of highly efficient rotor profile and special advanced KAPP rotor milling lathe, ensuring higher processing precision and working efficiency, improving the reliability of compressor operation.

### 2. Falling Film Evaporator with highly effective heat transfer performance

The heat transfer performance of falling film evaporator is about 30% higher than flooded evaporator. Introducing special designed distributor and processing technology, the liquid refrigerant on the surface of heat exchange tube in the falling film area can be evenly formed into the film, which has a great advantage over boiling evaporation.

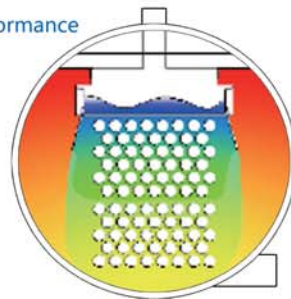

### 3. Widely application

The chiller can realize excellent performance not only in normal chilled water application, but also in -20°C outlet chilled water and over 80°C outlet hot water.

### 4.Environmental friendly and energy saving

Adopt R134a which has no damage to the ozone layer. Refrigerant charging quantity: 0.20~0.25kg/kW, 30~40% less than flooded compressor unit, which can fully reduce the greenhouse effect.

Among the alternative refrigerant which can replace R22, working pressure of R134a is about 50% lower than R404A and R507. The rotor leakage is reduced because of low pressure difference of R134a compressor, and the adiabatic efficiency and volumetric efficiency are improved compared with R404A and R507. The theoretical cycle efficiency of R134a is 12% higher than R404A and 6% higher than R507 on average, which is an obvious advantage of energy-saving over R404A and R507. Therefore, although the cost of R134a unit is higher than that of R404A and R507 due to the low refrigerating capacity per unit of swept volume, the BingShan falling film refrigerating units still have a full range of products with R134a refrigerant.

The energy efficiency ratio of LS series falling film semi-hermetic screw water chiller is above grade I or II of national regulation GB19577. Due to the small temperature difference between glycol/brine outlet temperature and evaporating temperature, the energy efficiency ratio of YC/YS series falling film glycol/brine unit is 12~15% higher than dry glycol/brine unit and 5~10% higher than flooded glycol/brine unit.

## 5. Stable running

Adopt calculating opening control algorithm to calculate the best opening of electronic expansion valve according to the evaporating pressure, condensing pressure, compressor energy class, etc., which keeps the liquid level stable under various condition and ensures unit stable running.

Separating efficiency of oil separator is above 99.99%, which reduces the reliance on oil return and the liquid refrigerant quantity that come into compressor through ejector loop, avoids lowering the viscosity of the lubricating oil because of excessive liquid refrigerant which affects the service life of the compressor bearings, and keep the compressor long-term stable running.

## 6. Convenient operation and high intelligence

Convenient installation, just connect water pipe and power.

Large colored touch screen, free switch between manual control and automatic control.

Adopt special microcomputer controller and high intellectualization.

To realize Remote networking monitoring through the RS-485 /MODBUS protocol.

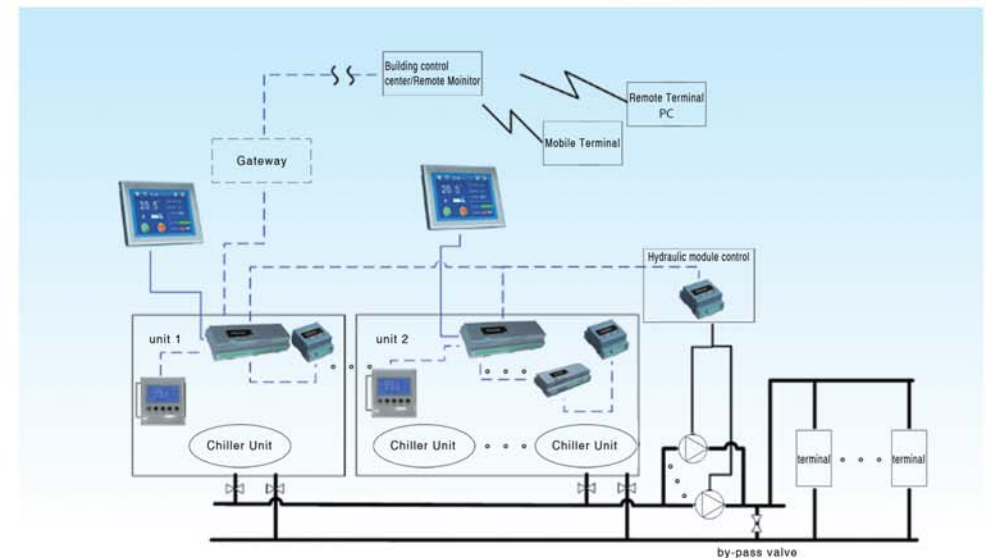



**Specification of LS Series Water Chiller**

Model	-	LS055A1A	LS075A1A	LS090A1A	LS110A1A	LS140A1A	LS160A1A	LS185A1A	LS210A1A	LS230A1A	LS270A1A	LS295A1A	LS370A1A	LS415A1A	LS330A2A	LS380A2A	LS425A2A	LS495A2A	LS550A2A	LS615A2A	LS750A2A	LS835A2A		
Cooling Capacity	USRT	54	73	86	107	138	158	181	205	225	264	289	362	406	323	372	416	484	538	602	734	817		
	kW	189	258	303	377	484	557	636	722	792	929	1017	1271	1428	1135	1307	1462	1702	1892	2117	2580	2872		
Compressor	Type and Number	Semi-hermetic Screw Compressor: 1										Semi-hermetic Screw Compressor: 2												
	Capacity Adjusting	4 grade/stepless adjustment within scope of 25%~100%										8 grade/stepless adjustment within scope of 25%~100%												
	Shaft Power	kW	41.2	55.7	64.7	81.0	104.3	109.7	122.5	141.1	154.5	182.1	198.7	231.5	259.6	207.5	239.6	267.6	310.4	342.8	381.6	461.9	515.9	
	Running Current	A	88	119	135	180	218	237	275	320	365	404	450	530	580	474	550	640	730	810	900	1060	1280	
	Max. Running Current	A	200	233	255	260	407	422	443	583	583	753	753	1098	1221	422	443	583	583	753	753	1098	1221	
	Starting Current	A	73	96	112	140	181	192	212	252	274	328	341	406	451	369	418	488	553	612	682	777	888	
	Power Standard	-	380V 50Hz 3Ph																					
	COP	-	4.59	4.63	4.69	4.65	4.64	5.08	5.19	5.12	5.13	5.10	5.12	5.49	5.50	5.47	5.45	5.46	5.48	5.52	5.55	5.59	5.57	
Chilled Water	Inlet Temp.	°C	12	12	12	12	12	12	12	12	12	12	12	12	12	12	12	12	12	12	12	12		
	Outlet Temp.	°C	7	7	7	7	7	7	7	7	7	7	7	7	7	7	7	7	7	7	7	7		
	Flow Rate	m <sup>3</sup> /h	32.5	44.4	52.1	64.8	83.3	95.8	109.3	124.2	136.3	159.7	174.9	218.7	245.6	195.3	224.8	251.5	292.7	325.5	364.2	443.7	494.0	
	Passes	-	2	2	2	2	2	2	2	2	2	2	2	2	2	2	2	2	2	2	2	2	2	
	Pressure Drop	kPa	58	70	69	77	77	72	77	78	74	79	77	86	86	65	69	83	80	87	83	82	82	
	Design Pressure	MPa(g)	1.0																					
Cooling Water	Inlet Temp.	°C	32	32	32	32	32	32	32	32	32	32	32	32	32	32	32	32	32	32	32	32		
	Outlet Temp.	°C	37	37	37	37	37	37	37	37	37	37	37	37	37	37	37	37	37	37	37	37		
	Flow Rate	m <sup>3</sup> /h	39.5	54.0	63.3	78.7	101.2	114.7	130.4	148.5	162.8	191.0	191.0	258.5	290.2	230.9	266.0	297.5	346.0	384.4	429.8	523.1	582.6	
	Passes	-	2	2	2	2	2	2	2	2	2	2	2	2	2	2	2	2	2	2	2	2	2	
	Pressure Drop	kPa	49	58	59	61	63	64	62	63	62	62	62	65	66	54	53	68	68	68	68	68	67	
	Design Pressure	MPa(g)	1.0																					
Dimension	Length	mm	3080	3080	3080	3079	3130	3774	3780	3774	3773	3850	3850	4320	4337	5470	5470	6270	6270	6484	6484	6517	6517	
	Width	mm	1370	1370	1390	1389	1385	1475	1480	1681	1681	1860	1860	1834	1838	1710	1710	1732	1734	1880	1905	1962	2010	
	Height	mm	1480	1480	1504	1579	1792	1832	1780	2090	2092	2075	2075	2402	2404	1880	1880	2244	2243	2270	2270	2553	2600	
Refrigerant	Type	-	R134a																					
	Charging Quantity	kg	50	65	70	80	110	130	140	160	170	205	205	260	285	210	260	295	330	350	420	510	580	
Weight	Net Weight	kg	2540	2630	2690	2810	2950	3320	3650	3820	4000	4230	4230	4910	5320	5610	5930	6310	6820	7610	8630	9810	11230	
	Running Weight	kg	2950	3070	3210	3580	3780	4180	4670	4910	5120	5320	5320	6290	6780	7180	7620	8040	8530	9520	10790	12260	13450	

Model	-	LS085A1P	LS095A1P	LS110A1P	LS130A1P	LS145A1P	LS170A1P	LS190A1P	LS215A1P	LS245A1P	LS280A1P	LS310A1P	LS375A1P	LS420A1P	
Cooling Capacity	USRT	83	93	106	124	140	164	186	210	239	274	303	367	410	
	kW	292	326	372	437	491	577	655	739	840	962	1065	1290	1441	
Compressor	Type and Number	Semi-hermetic Screw Compressor: 1													
	Capacity Adjusting	4 grade/stepless adjustment within scope of 25%~100%													
	Shaft Power	kW	52.7	58.4	66.0	76.9	86.1	100.8	114.1	132.9	150.7	172.6	190.6	226.3	252.8
	Running Current	A	91	100	114	137	147	179	201	243	266	305	339	391	431
	Max. Running Current	A	121	132	151	178	197	230	254	320	365	405	450	530	580
	Starting Current	A	233	270	328	392	440	528	630	583	583	753	753	1098	1221
	Power Standard	-	380V 50Hz 3Ph												
	COP	-	5.55	5.59	5.64	5.68	5.71	5.73	5.73	5.56	5.58	5.58	5.59	5.70	5.70
Chilled Water	Inlet Temp.	°C	12	12	12	12	12	12	12	12	12	12	12	12	
	Outlet Temp.	°C	7	7	7	7	7	7	7	7	7	7	7	7	
	Flow Rate	m <sup>3</sup> /h	50.2	56.1	64.0	75.1	84.5	99.3	12.6	127.0	144.5	165.5	183.2	221.8	247.9
	Passes	-	4	4	4	4	4	4	4	2	2	2	2	2	
	Pressure Drop	kPa	77	73	77	80	85	73	80	62	62	60	64	62	61
	Design Pressure	MPa(g)	1.0												
Cooling Water	Inlet Temp.	°C	32	32	32	32	32	32	32	32	32	32	32	32	
	Outlet Temp.	°C	37	37	37	37	37	37	37	37	37	37	37	37	
	Flow Rate	m <sup>3</sup> /h	59.3	66.2	75.4	88.3	99.3	116.6	132.2	149.9	170.4	195.2	215.9	260.7	291.3
	Passes	-	4	4	4	4	4	4	4	2	2	2	2	2	
	Pressure Drop	kPa	76	75	74	74	73	75	75	50	50	50	50	50	
	Design Pressure	MPa(g)	1.0												
Dimension	Length	mm	2760	2780	2800	2820	2820	2850	2850	4180	4180	4250	4250	4340	4340
	Width	mm	1650	1670	1690	1720	1720	1790	1790	1710	1710	1910	1910	1865	1940
	Height	mm	2020	2050	2075	2080	2100	2150	2170	2100	2100	2100	2100	2430	2430
Refrigerant	Type	-	R134a												
	Charging Quantity	kg	75	85	95	10	125	145	170	210	210	245	270	322	370
Weight	Net Weight	kg	2980	3120	3230	3360	3450	3540	4380	4800	4800	5040	5280	5880	6360
	Running Weight	kg	3380	3590	3820	4010	4120	4230	5230	5740	5740	5940	6310	7060	7620

- Standard condition:
- ▶ Chilled water inlet temp: 12°C
  - ▶ Chilled water outlet temp: 7°C
  - ▶ Cooling water inlet temp: 32°C
  - ▶ Cooling water outlet temp: 37°C

Note:

- Cooling water inlet/outlet temp: 32/37°C. The temperature and flow rate of chilled water and cooling water are based on GB/T18430.1 requirements.
- Chilled water lateral fouling factor: 0.018m<sup>2</sup>·°C/kW, Cooling water lateral fouling factor: 0.044m<sup>2</sup>·°C/kW
- Not including auxiliary engine power

**Specification of RB Series Water (Ground) Source Heat Pump**

Model	-	RB028A1A	RB039A1A	RB044A1A	RB058A1A	RB074A1A	RB080A1A	RB093A1A	RB104A1A	RB118A1A	RB132A1A	RB147A1A	RB182A1A	RB202A1A	RB163A2A	RB190A2A	RB212A2A	RB240A2A	RB270A2A	RB300A2A	RB371A2A	LS413A2A	
Nominal Cooling Capacity	kW	191	261	307	381	490	564	644	731	802	940	1030	1287	1445	1149	1323	1480	1723	1916	2143	2611	2907	
Nominal Heating Capacity	kW	278	388	442	583	740	797	928	1036	1175	1324	1471	1817	2021	1626	1895	2115	2399	2703	3004	3711	4127	
Type and Number	-	Semi-hermetic Screw Compressor: 1										Semi-hermetic Screw Compressor: 1											
Capacity Adjusting	-	4 grade/stepless adjustment within scope of 25%~100%										4 grade/stepless adjustment within scope of 25%~100%											
Cooling Shaft Power	kW	39.5	53.6	62.1	77.8	100.2	105.4	118.0	135.6	148.4	175.0	190.9	222.4	249.4	199.3	230.2	257.1	298.2	329.4	366.7	443.8	495.7	
Cooling Running Current	A	71	93	109	136	176	186	207	245	266	318	331	394	437	357	405	473	536	593	661	753	861	
Heating Shaft Power	kW	48.6	67.5	76.1	99.0	124.0	134.6	153.5	176.6	198.4	221.9	244.6	286.4	318.5	269.3	306.9	353.2	396.8	443.8	489.3	572.7	636.8	
Heating Running Current	A	85	114	130	168	210	227	259	308	343	390	425	492	547	455	518	616	685	779	851	983	1093	
Max. Running Current	A	88	119	135	180	218	237	275	320	365	404	450	530	580	474	550	640	730	810	900	1060	1280	
Starting Current	A	200	233	255	260	407	422	443	583	583	753	753	1098	1221	422	443	583	583	753	753	1098	1221	
Electricity	-	380V 50Hz 3Ph																					
Cooling COP	-	4.83	4.88	4.94	4.90	4.89	5.35	5.45	5.39	5.40	5.37	5.39	5.79	5.80	5.77	5.75	5.76	5.78	5.82	5.84	5.88	5.86	
Heating COP	-	5.72	5.76	5.80	5.89	5.97	5.92	6.05	5.87	5.92	5.97	6.01	6.34	6.34	6.04	6.17	5.99	6.05	6.09	6.14	6.48	6.48	
COP	-	5.22	5.27	5.32	5.33	5.36	5.60	5.71	5.60	5.63	5.67	5.67	6.03	6.04	5.89	5.93	5.86	5.89	5.94	5.97	6.15	6.14	
Inlet Temp.	°C	12	12	12	12	12	12	12	12	12	12	12	12	12	12	12	12	12	12	12	12	12	
Outlet Temp.	°C	7	7	7	7	7	7	7	7	7	7	7	7	7	7	7	7	7	7	7	7	7	
Flow Rate	m <sup>3</sup> /h	32.9	45.0	52.8	65.6	84.3	97.0	110.7	125.8	137.9	161.7	177.1	221.4	248.6	197.7	227.6	254.6	296.3	329.5	368.7	449.2	500.1	
Passes	-	2	2	2	2	2	2	2	2	2	2	2	2	2	2	2	2	2	2	2	2	2	
Pressure Drop	kPa	56	54	58	55	57	54	57	56	56	57	57	56	55	57	56	54	56	55	58	56	57	
Dia. Of Pipe	B	100	100	100	100	125	150	150	150	150	200	200	200	200	200	200	200	250	250	250	250	300	
Design Pressure	MPa(g)	1.0																					
Inlet Temp.	°C	30	30	30	30	30	30	30	30	30	30	30	30	30	30	30	30	30	30	30	30	30	
Outlet Temp.	°C	34.8	34.8	34.8	34.8	34.8	34.7	34.7	34.7	34.7	34.7	34.7	34.7	34.7	34.7	34.7	34.7	34.7	34.7	34.7	34.7	34.7	
Flow Rate	m <sup>3</sup> /h	41.1	56.2	66.0	81.9	105.4	121.3	138.4	157.2	172.4	202.1	221.4	276.7	310.8	247.1	284.5	318.2	370.4	411.9	460.8	561.4	625.1	
Passes	-	2	2	2	2	2	2	2	2	2	2	2	2	2	2	2	2	2	2	2	2	2	
Pressure Drop	kPa	54	64	65	68	67	72	73	71	72	71	72	76	77	63	62	79	79	80	80	80	79	
Dia. Of Pipe	B	100	100	100	100	125	150	150	150	150	200	200	200	200	200	200	200	250	250	250	300	300	
Design Pressure	MPa(g)	1.0																					
Heating Condition Water Lateral Pressure Loss of Evaporator	kPa	88	84	91	86	89	84	89	88	88	89	89	88	86	89	88	84	88	86	91	88	89	
Heating Condition Water Lateral Pressure Loss of Condenser	kPa	35	41	42	44	43	46	47	45	46	45	46	49	49	40	40	51	51	51	51	51	51	
Length	mm	3080	3080	3080	3079	3130	3780	3780	3780	3773	3850	3848	4320	4337	5470	5470	6270	6270	6484	6484	6517	6517	
Width	mm	1340	1340	1370	1430	1425	1495	1520	1540	1730	1910	1910	1885	1890	1630	1630	1755	1785	1930	1955	2020	2070	
Height	mm	1480	1480	1504	1579	1792	1760	1780	1850	2092	2075	2075	2402	2404	1830	1830	2240	2243	2270	2270	2553	2600	
Type	-	R134a																					
Charging Quantity	kg	50	65	70	80	110	130	140	160	170	205	210	260	285	210	260	295	330	350	420	510	580	
Net Weight	kg	2580	2670	2730	2850	2990	3360	3690	3860	4040	4270	4430	4950	5360	5690	6010	6390	6900	7690	8710	9890	11310	
Running Weight	kg	2990	3110	3250	3620	3820	4220	4710	4950	5160	5360	5670	6330	6820	7260	7700	8120	8610	9600	10870	12340	13530	

**Water circulation refrigerating condition:**

- ▶ Using lateral water inlet temp: 12°C
- ▶ Using lateral water outlet temp: 7°C
- ▶ Heating lateral water inlet temp: 30°C
- ▶ Heating lateral water outlet temp: 34.7°C

**Water circulation refrigerating condition:**

- ▶ Using lateral water outlet temp: 45°C
- ▶ Heating lateral water inlet temp: 20°C
- ▶ The water flow rate of using side and heating side is based on water circulation refrigerating condition.

**Note :**

- The temperature and flow rate of chilled water and cooling water are based on GB/T19409 requirements.
- Chilled water lateral fouling factor: 0.018m<sup>2</sup>·°C/kW, Cooling water lateral fouling factor: 0.044m<sup>2</sup>·°C/kW
- Not including auxiliary engine power

**Specification of YC/YS Series Glycol/Brine Unit**

Model	-	YC030A1A	YC040A1A	YC045A1A	YC060A1A	YC075A1A	YC080A1A	YC095A1A	YC105A1A	YC120A1A	YC135A1A	YC150A1A	YC180A1A	YC200A1A	YC160A2A	YC190A2A	YC210A2A	YC210A2A	YC270A2A	YC300A2A	YC365A2A	YC405A2A	
Cooling Capacity	USRT	28	39	44	59	74	80	94	104	118	134	148	181	202	160	188	208	237	267	297	363	403	
	kW	98	137	155	208	262	282	330	366	416	470	522	638	709	564	660	732	832	938	1044	1276	1418	
Compressor	Type and Number	Semi-hermetic Screw Compressor: 1											Semi-hermetic Screw Compressor: 2										
	Capacity Adjusting	4 grade/stepless adjustment within scope of 25%~100%											8 grade/stepless adjustment within scope of 25%~100%										
35% Glycol Solution	Shaft Power	kW	34.4	47.7	53.8	70.0	87.6	95.2	108.5	124.8	140.2	156.8	172.9	195.6	217.5	190.4	217.0	249.6	280.4	33.6	345.8	391.0	435.0
	Running Current	A	63.1	82.6	94.8	123.0	156.0	169.4	191.2	226.4	249.3	288.8	312.0	333.9	371.3	338.8	382.4	452.8	498.6	577.6	624.0	677.8	742.6
Cooling Water	COP	-	2.85	2.87	2.88	2.97	2.99	2.96	3.04	2.93	2.97	2.99	3.02	3.26	3.26	2.96	3.04	2.9	2.97	27.92	3.02	3.26	3.26
	Inlet Temp	°C	-7.0	-7.0	-7.0	-7.0	-7.0	-7.0	-7.0	-7.0	-7.0	-7.0	-7.0	-7.0	-7.0	-7.0	-7.0	-7.0	-7.0	-7.0	-7.0	-7.0	-7.0
	Outlet Temp	°C	-10.0	-10.0	-10.0	-10.0	-10.0	-10.0	-10.0	-10.0	-10.0	-10.0	-10.0	-10.0	-10.0	-10.0	-10.0	-10.0	-10.0	-10.0	-10.0	-10.0	-10.0
	Flow Rate	m³/h	31.9	44.6	50.5	67.8	85.4	91.9	107.5	119.3	135.6	153.2	170.1	207.9	231.0	183.8	215.1	238.5	271.1	305.7	340.2	415.8	462.1
	Pressures	-	2	2	2	2	2	2	2	2	2	2	2	2	2	2	2	2	2	2	2	2	2
	Pressure Drop	kPa	77	77	75	80	86	82	86	87	83	88	84	96	93	70	72	76	74	78	76	80	79
	Dia. Of Pipe	B	100	100	100	100	125	150	150	150	150	200	200	200	200	200	200	200	250	250	250	250	300
	Design Pressure	MPa(g)	1.0											1.0									
Dimension	Inlet Temp	°C	30	30	30	30	30	30	30	30	30	30	30	20	30	30	30	30	30	30	30	30	
	Outlet Temp	°C	35	35	35	35	35	35	35	35	35	35	35	35	35	35	35	35	35	35	35	35	
	Flow Rate	m³/h	22.8	31.8	35.9	47.8	60.1	64.9	75.4	84.4	95.6	107.8	119.5	143.4	159.3	129.7	150.8	168.8	191.3	167.1	239.0	286.7	318.7
	Pressures	-	2	2	2	2	2	2	2	2	2	2	2	2	2	2	2	2	2	2	2	2	2
Refrigerant	Pressure Drop	kPa	60	62	63	61	64	68	69	72	71	72	70	75	74	78	74	76	73	79	75	77	74
	Dia. Of Pipe	B	100	100	100	100	125	150	150	150	150	200	200	200	200	200	200	200	250	250	250	300	300
	Design Pressure	MPa(g)	1.0											1.0									
Weight	Length	mm	3760	3760	3760	3765	3765	3780	3780	3780	3773	3850	3848	4320	4337	5470	5470	6270	6270	6484	6484	6517	6517
	Width	mm	1180	1180	1210	1250	1250	1310	1330	1350	1510	1680	1680	1650	1660	1430	1420	1540	1560	1690	1720	1770	1810
	Height	mm	1480	1480	1504	1579	1792	1760	1780	1850	2092	2075	2075	2402	2404	1830	1830	2240	2243	2270	2270	2553	2600
Refrigerant	Type	-	R134a																				
	Charging Quantity	kg	45	60	65	70	100	120	125	145	155	185	190	235	255	190	235	265	300	315	380	460	520
	Net Weight	kg	2290	2370	2420	2530	2655	2990	3290	3440	3600	3810	3950	4420	4790	5050	5340	5680	6140	6850	7770	8830	10100
Weight	Running Weight	kg	2660	2760	2890	3220	3400	3760	4200	4420	4610	4790	5070	5660	6100	6460	6560	7235	7680	8570	9710	11030	12100

**Air-conditioning condition:**

- ▶ Glycol/Brine inlet temp: -7°C
- ▶ Glycol/Brine outlet temp: -10°C
- ▶ Cooling water inlet temp: 30°C
- ▶ Cooling water outlet temp: 35°C

**Note :**

- The data of YC series glycol unit can be used for YS series brine unit, but the evaporator materials are different. Please mind that when selecting.
- The water temperature difference and flow rate of the evaporator are the recommended parameters to ensure the best performance of the whole machine. There should not be much deflection when install.
- The above data are for reference only. Please consult our salesmen for technical parameters under other conditions.
- Glycol/Brine lateral fouling factor: 0.018m²·°C/kW, Cooling water lateral fouling factor: 0.044m²·°C/kW Not including auxiliary engine power.



## Dimension and Installation Drawing

LS055A1A~LS415A1A and LS215A1P~LA420A1P Dimension and Installation Drawing

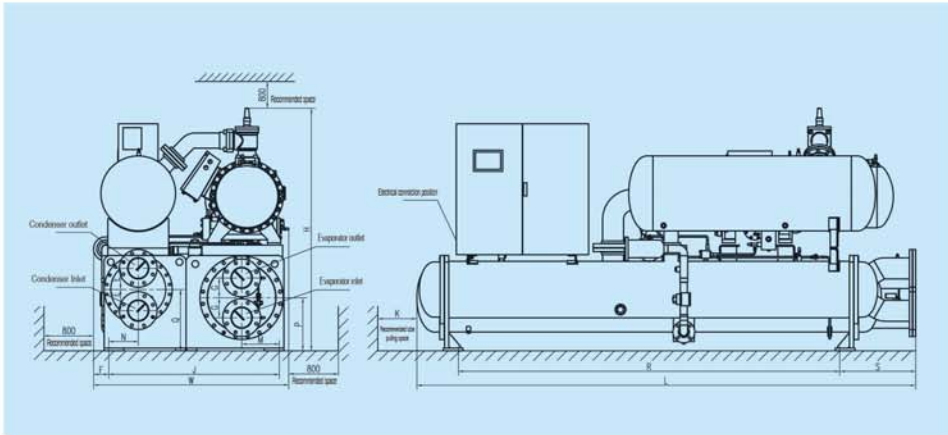

- Note :
- The heat exchanger water inlet/outlet pipe must be supported to minimize the load on the unit.
  - Both the evaporator and the condenser are equipped with empty and drain water joint.
  - All the heat exchangers with 2 passes shown above are connected on the right side.
  - The dimensions are only for reference. Please contact our technical support staff for exact dimensions

Dimension Model	L	W	H	A	B	E	F	G	J	K	M	N	P	Q	R	S
LS055A1A	3080	1310	1480	100	100	120	186	120	1030	2400	200	175	295	360	2284	509
LS075A1A	3080	1310	1480	100	100	120	162	120	1030	2400	200	175	295	360	2284	509
LS090A1A	3080	1310	1505	100	100	120	151	120	1050	2400	222	175	313	360	2284	509
LS110A1A	3079	1410	1579	100	100	120	154	120	1145	2400	223	175	313	380	2284	509
LS140A1A	3130	1385	1792	125	125	135	121	135	1195	2400	250	200	400	450	2284	542
LS160A1A	3774	1475	1832	150	150	145	145	150	1260	3000	280	223	400	463	2884	571
LS185A1A	3780	1480	1780	150	150	160	114	150	1290	3000	285	223	400	463	2884	575
LS210A1A	3774	1681	2090	150	150	160	138	150	1440	3000	285	235	400	470	2884	575
LS230A1A	3773	1681	2092	150	150	150	108	150	1470	3000	285	285	380	473	2884	574
LS270A1A	3850	1860	2075	200	200	175	144	175	1550	3000	305	285	400	470	2884	633
LS295A1A	3848	1859	2075	200	200	175	144	175	1550	3000	305	285	400	470	2884	633
LS370A1A	4320	1834	2402	200	200	185	149	185	1565	3400	330	305	450	550	3284	690
LS415A1A	4337	1838	2404	200	200	185	123	210	1620	3400	355	305	450	550	3284	690
LS215A1P	4180	1710	2100	150	150	175	108	150	1410	3400	285	270	400	510	3284	600
LS245A1P	4180	1710	2100	200	200	175	142	175	1410	3400	285	270	400	510	3284	600
LS280A1P	4250	1910	2100	200	200	175	144	175	1550	3400	330	285	425	470	3284	633
LS310A1P	4250	1910	2100	200	200	175	144	175	1550	3400	330	285	425	470	3284	633
LS375A1P	4340	1865	2430	200	200	175	149	175	1620	3400	325	310	450	535	3284	690
LS420A1P	4340	1940	2430	200	200	185	123	185	1650	3400	400	320	495	580	3284	690

LS085A1P~LS190A1P Dimension and Installation Drawing

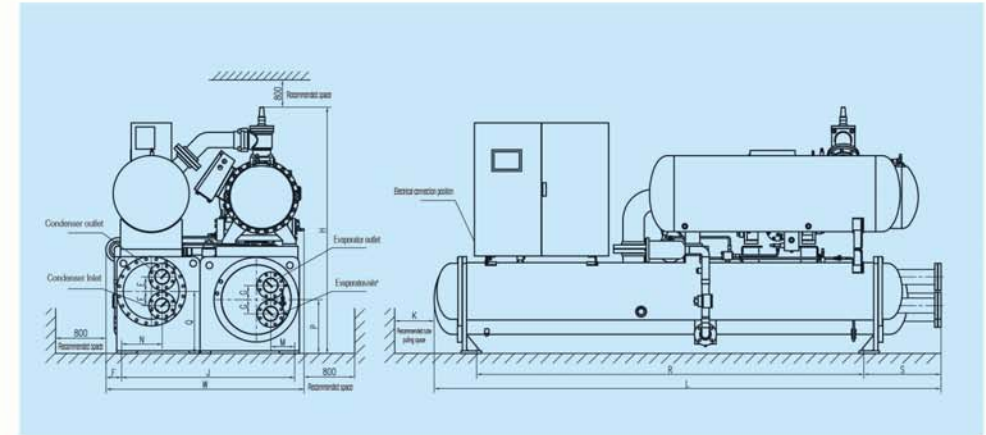

- Note :
- The heat exchanger water inlet/outlet pipe must be supported to minimize the load on the unit.
  - Both the evaporator and the condenser are equipped with empty and drain water joint.
  - All the heat exchangers with 2 passes shown above are connected on the right side.
  - The dimensions are only for reference. Please contact our technical support staff for exact dimensions

Dimension Model	L	W	H	A	B	E	F	G	J	K	M	N	P	Q	R	S
LS085A1P	2760	1650	2020	100	100	120	124	120	1440	2000	160	240	400	463	1884	505
LS095A1P	2780	1670	2050	100	100	120	110	120	1460	2000	165	240	400	465	1884	515
LS110A1P	2800	1690	2075	125	125	135	108	135	1490	2000	165	245	400	465	1884	525
LS130A1P	2820	1720	2080	125	125	135	135	135	1520	2000	175	250	400	470	1884	540
LS145A1P	2820	1720	2100	125	125	135	126	135	1520	2000	175	250	400	470	1884	540
LS170A1P	2850	1790	2150	150	150	150	120	150	1600	2000	180	260	475	540	1884	570
LS190A1P	2850	1790	2170	150	150	150	115	150	1600	2000	185	260	475	540	1884	570

## Dimension and Installation Drawing

### LS330A2A~LS835A2A Dimension and Installation Drawing

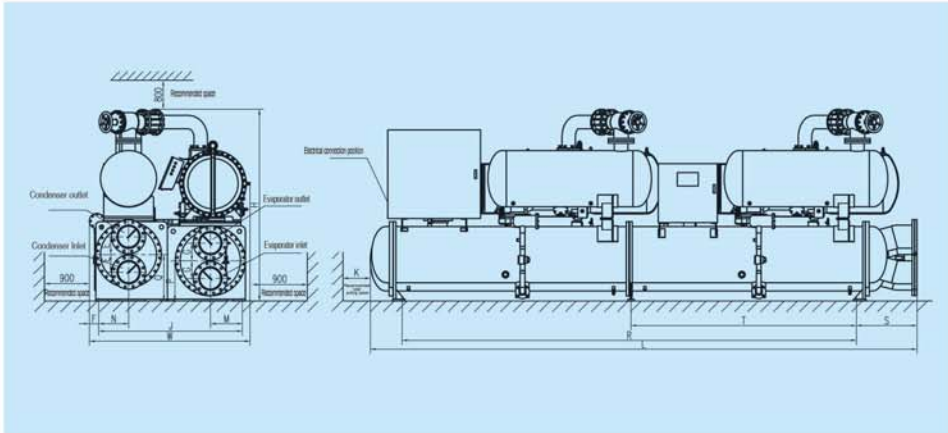

- Note :
- The heat exchanger water inlet/outlet pipe must be supported to minimize the load on the unit.
  - Both the evaporator and the condenser are equipped with empty and drain water joint.
  - All the heat exchangers with 2 passes shown above are connected on the right side.
  - The dimension of maintenance space K mentioned above can be determined according to the selected heat exchange tube cleaning method.
  - If the damaged heat exchanger tube needs to be replaced, one of the tube parts of the heat exchanger should be removed and place aside to allow for the space to operate.
  - The dimensions are only for reference. Please contact our technical support staff for exact dimensions

Dimension Model	L	W	H	A	B	E	F	G	J	M	N	P	Q	R	S	T
LS330A2A	5470	1710	1880	200	200	175	277	175	1395	330	285	450	470	4387	720	2174
LS380A2A	5470	1710	1880	200	200	175	277	175	1395	330	285	450	470	4387	720	2174
LS425A2A	6270	1732	2244	200	200	175	119	210	1580	355	305	460	550	5187	720	2574
LS495A2A	6270	1734	2243	250	250	210	104	210	1595	355	330	460	550	5187	717	2574
LS550A2A	6484	1880	2270	250	250	210	115	210	1675	380	330	475	570	5387	720	2674
LS615A2A	6484	1905	2270	250	250	210	110	210	1705	380	356	475	550	5387	720	2674
LS750A2A	6517	1962	2553	300	250	235	137	210	1790	430	370	525	625	5387	720	2674
LS835A2A	6517	2010	2600	300	300	235	126	235	1840	480	370	575	625	5387	720	2674

### LS series falling film semi-hermetic screw water chiller installation drawing

Dimension Model	A	B	C	D	E	F
LS055A1A	2284	2584	2784	1030	1230	1430
LS075A1A	2284	2584	2784	1030	1230	1430
LS090A1A	2284	2584	2784	1050	1250	1450
LS110A1A	2284	2584	2784	1145	1345	1545
LS140A1A	2284	2584	2784	1195	1395	1595
LS160A1A	2884	3184	3384	1265	1465	1665
LS185A1A	2884	3184	3384	1290	1490	1690
LS210A1A	2884	3184	3384	1320	1520	1720
LS230A1A	2884	3184	3384	1470	1670	1970
LS270A1A	2884	3184	3384	1550	1750	1950
LS295A1A	2884	3184	3384	1550	1750	0195
LS370A1A	3284	3584	3784	1565	1765	1965
LS415A1A	3284	3584	3784	1620	1820	2020
LS330A2A	4387	4687	4887	1395	1595	1795
LS380A2A	4387	4687	4887	1395	1595	1795
LS425A2A	5187	5487	5687	1580	1780	1980
LS495A2A	5187	5487	5687	1595	1795	1995
LS550A2A	5387	5787	5987	1675	1875	2075
LS615A2A	5387	5787	5987	1705	1905	2105
LS750A2A	5387	5787	5987	1790	1990	2190
LS835A2A	5387	5787	5987	1840	2040	2240
LS085A1P	1884	2184	2384	1440	1640	1840
LS095A1P	1884	2184	2384	1460	1660	1860
LS110A1P	1884	2184	2384	1490	1690	1890
LS130A1P	1884	2184	2384	1520	1720	1920
LS145A1P	1884	2184	2384	1520	1720	1920
LS170A1P	1884	2184	2384	1600	1800	2000
LS190A1P	1884	2184	2384	1600	1800	2000
LS215A1P	3284	3584	3784	1410	1610	1810
LS245A1P	3284	3584	3784	1410	1610	1810
LS280A1P	3284	3584	3784	1550	1750	19050
LS310A1P	3284	3584	3784	1550	1750	195
LS375A1P	3284	3584	3784	1620	1820	2020
LS420A1P	3284	3584	3784	1650	1850	2050

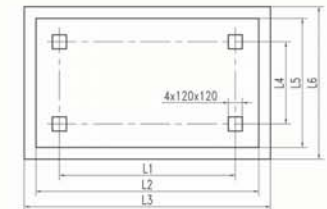

Due to the limited space, the dimensions and installation drawings of RB series water (ground) source heat pump unit and YC/YS series glycol/brine unit are not provided. If there are any requirements, please consult with us

All the data, subject to change, are only for reference.